

MiniBlue™ II

Hot Melt Dispensing Applicators

Compact hot melt guns deliver industry-best service life and superior, consistent high-speed performance

Features

Nordson MiniBlue II applicators set the new industry standard for speed, reliability and performance. Ideal for operations with close flap-compression sections or smaller flaps with shorter adhesive beads, these applicators deliver consistent, robust performance.

- Module features advanced seal technology (patented and patent pending) and high-speed capability
- Innovative solenoid technology and advanced module design delivers fast (2ms) cycle times and superior high-speed performance
- Module and solenoid combination reduces the performance gap between pneumatic and electric applicators
- Backward compatibility with previous MiniBlue applicators
- Compact design for confined spaces
- Choice of solenoids, Saturn® solenoids and nozzles, module widths, single- or multi-module, and water wash configurations
- Standard hard-plastic insulating cover on MiniBlue II (slim) applicators for energy efficiency and protection from incidental contact

Benefits

- More than twice the operating life of any pneumatic applicator in the packaging industry; over 100 million switching cycles*
- Less frequent replacement, downtime, maintenance, and inventory costs
- Enhanced ball-and-seat design provides stronger air-open/air-close force for cleaner operation at high speeds
- Integrated filter captures contaminants, reducing nozzle clogs and downtime
- Quick-disconnect feature minimizes solenoid installation and removal downtime
- Insulating covers reduce energy use up to 40 percent; minimize contact with heated surfaces; maintain applicator and adhesive temperature for better flow, cutoff and bonding
- Configurable product maximizes pattern, adhesive and application flexibility to reduce costs

*adhesive dependent

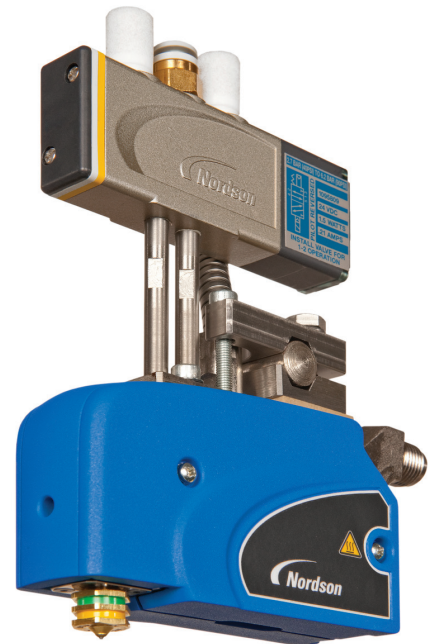

MiniBlue™ II Hot Melt Dispensing Applicators

Specifications

Operating Temperature	204° C (400° F) maximum
Operating Air Pressure¹	3.4 to 5.5 bar (50 to 80 psi)
Working Hydraulic Pressure	103 bar (1500 psi) maximum
Nozzles Standard	Saturn®, single orifice (controlled engagements)
Saturn Solenoid Valves	24 VDC, high-temperature, factory-installed
Electrical Service	240 VAC, 50/60 Hz; 200 VAC, 50/60 Hz optional
Maximum Cycle Rate	8000/min
Minimum Bead Deposition	2ms (adhesive dependent)
Adhesive Viscosity	500 - 5000 cps

¹ Recommended range. Dry, regulated, unlubricated air required for consistent gun operation.

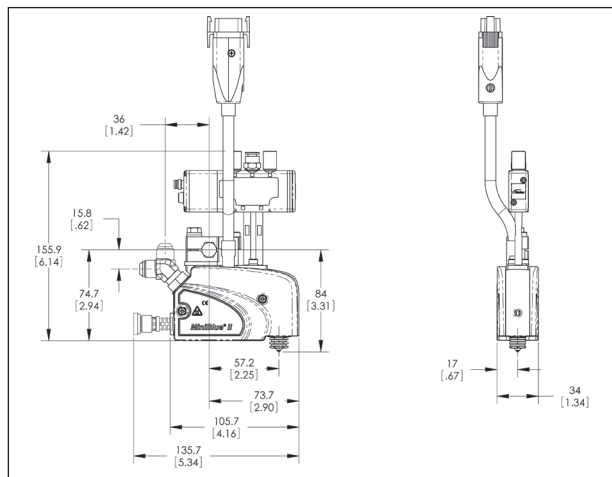

MiniBlue II (Slim) Applicator with Saturn SP solenoid and hard-plastic insulating gun cover

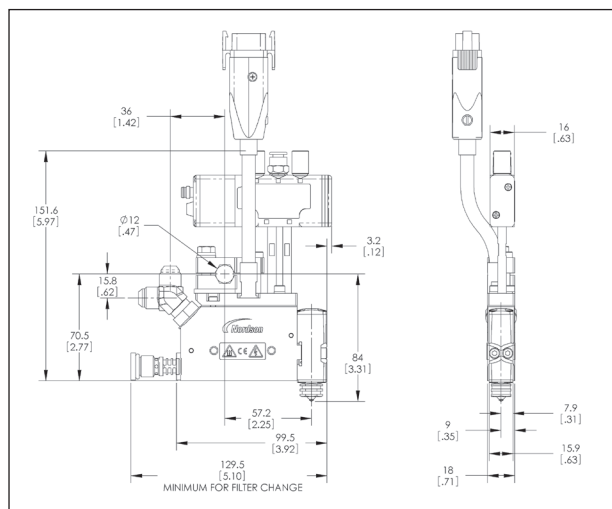

MiniBlue II (Slim) Applicator with Saturn SP solenoid

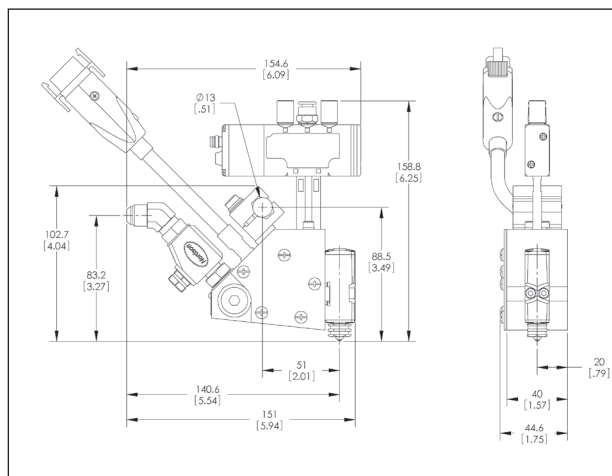

MiniBlue II (Wide) Applicator with Saturn SP solenoid

For more information, speak with your Nordson representative or contact your Nordson regional office.

United States

Duluth, Georgia
(800) 683-2314 **Phone**
(866) 667-3329 **Fax**

Canada

Markham, Ontario
(800) 463-3200 **Phone**
(905) 475-8821 **Fax**

Europe

Erkrath, Germany
(49) 211-9205-0 **Phone**
(49) 211-254658 **Fax**

Japan

Tokyo, Japan
(81) 3-5762-2700 **Phone**
(81) 3-5762-2701 **Fax**

Asia/Australia/ Latin America

Amherst, Ohio
(440) 985-4797 **Phone**
(440) 985-1096 **Fax**

PKL-10-5604
Reissued 1/11
© 2010 Nordson Corporation
All Rights Reserved.
Printed in U.S.A.
Nordson reserves the right to make design changes between printings.