

Model LF-10 and Model HF-10 Automatic Powder Spray Guns



Electrostatic powder spray guns for high-performance automatic application of fusion bond epoxy powder coatings in high ambient temperature environments.

Nordson Model LF-10 and Model HF-10 corona-type automatic electrostatic powder guns are designed for the application of fusion bond epoxy powder coatings in exterior pipe coating applications in high ambient temperature environments. The Model LF-10 (Low Flow) spray gun is used in low- to medium-volume powder applications. The Model HF-10 (High Flow) spray gun is designed for high-volume applications.

The electrostatic power unit is capable of generating up to 100 KV for maximum transfer efficiency needed in high-speed, high-film build pipe coating lines.

Powder nozzles for the respective guns are available in a range of slot sizes to optimize powder spray patterns for the specific diameter of pipe being coated. Conversion kits are available to cost-effectively convert a LF-10 gun to a HF-10 gun, or the reverse, for maximum operating flexibility in varying production environments. Powder pumps and delivery tubing must also be changed accordingly.

Durable Construction

The gun body is constructed of lightweight, nonconductive-engineered plastic that further enhances the attraction of powder particles to the grounded parts being coated. A rugged high-strength electrostatic cable supplies voltage from the Versa-Spray® EXP-100 to the gun. The gun attaches to a standard Nordson 36-inch length gun-mounting bar for secure positioning and easy adjustment on stationary adjustable gun stands.

The Model LF-10 and Model HF-10 automatic guns feature remote triggering direct from a Versa-Spray control EXP 100 control unit via a Nordson® MC-3 remote control console, PLC or other triggering device.

Safe to Operate

The Model LF-10 and Model HF-10 guns, like all Nordson electrostatic equipment, meet the industry's strictest requirements for operating safety. These guns are also completely field repairable.

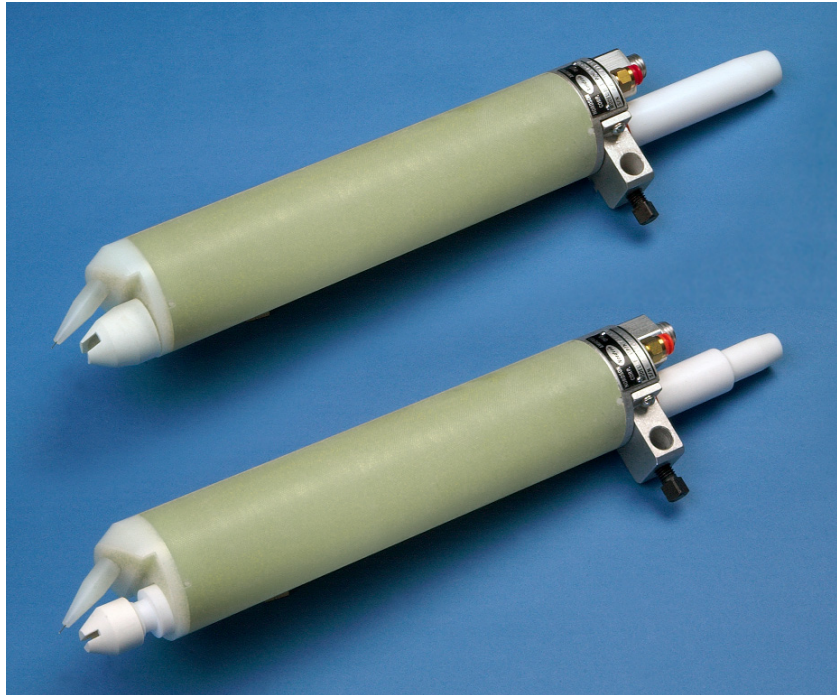

HF-10 gun (top) and LF-10 gun (bottom).

Easy to Clean and Maintain

The guns' powder pathway is a straight-through design and constructed of materials for increased wear resistance and minimal powder impact fusion. It can be easily removed without special tools for fast and efficient routine cleaning.

Features and Benefits

- **Connections at back of gun** – provide for easy installation and gun adjustment.
- **Modular construction** – fast, easy disassembly for routine cleaning and field service, minimizes downtime and maintenance costs.
- **Wear-resistant materials** – all powder pathway components are made of specially engineered materials for exceptional resistance to wear and powder impact fusion.
- **Optional nozzles** – a wide variety of flat-spray nozzles provide exceptional spray pattern versatility for optimum coating coverage and efficiency on a wide range of pipe diameters.
- **Cylindrical, air-cooled gun** – the shape of the gun minimizes powder build-up for easier cleaning. Compressed air to the gun provides cooling of the internal components.

Model LF-10 and Model HF-10 Automatic Powder Spray Guns

Versa-Spray® EXP-100 Control Unit

The Versa-Spray EXP-100 control unit supplies and controls electrostatic voltage to Nordson® Model LF-10 and Model HF-10 guns used in exterior pipe coating applications in high ambient temperature environments. It also regulates air and powder flow to the respective pumps for the LF-10 and HF-10 guns. The electrostatic charging pumps for the LF-10 and HF-10 guns. The electrostatic charging output is adjustable from 30 to 100 KV for increased field strength and optimum operating flexibility. Electrostatic cables are available in lengths of 8 meters (26 ft) or 16 meters (52 ft).

The control unit fits a standard 19-inch "instrument-type" rack cabinet. In a multiple-gun powder system, eight or ten units, a master control unit and all other system controls, including a programmable controller, can be mounted in one or more rack cabinets providing a complete, convenient "command center" for the entire powder coating operation. The rack-mount configuration of the Versa-Spray EXP-100 control unit also permits easy access for service to help minimize downtime.

A bright dual-function LED bar graph continuously displays either KV set point or micro amp current output. The display can easily be seen from a distance, providing operators with operational and diagnostic information at a glance.



Versa-Spray EXP-100 control unit

Nordson Powder Pumps

Nordson high-performance powder pumps utilize a venturi principle to deliver powder from a supply hopper to Nordson powder spray guns. Pumps and powder delivery tubing for pipe coating applications are sized according to either the LF-10 or HF-10 gun. Powder contact parts are made of specially engineered materials for increased resistance to wear and powder impact fusion. Pump operation is controlled by the Nordson Versa-Spray EXP-100 control unit.



Nordson powder pumps for LF-10 gun (top) and HF-10 gun (bottom).

Specifications

Dimensions

Weight

Without cable
740 grams (26 oz)

Length

Overall
355.6 mm (14 in)
Mounting hole forward
330.2 mm (13 in)

Height

With gun mount and tube bracket
133.4 mm (5.25 in)

Width

63.5 mm (2.5 in)

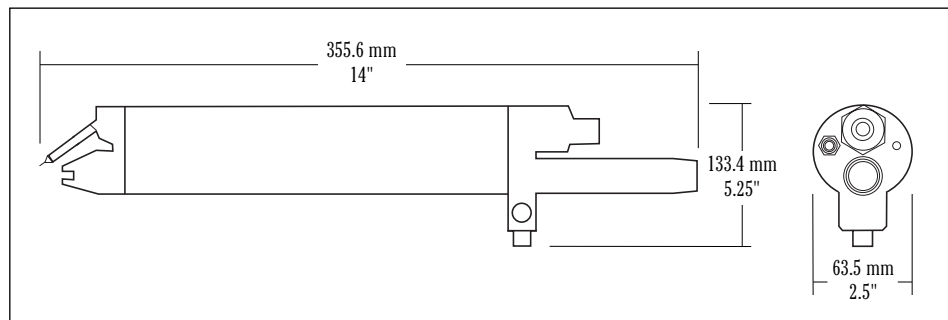

Figure 1

Nordson reserves the right to make design changes to products to improve their function. These changes may occur between printings.



For more information, talk with your Nordson representative or contact your Nordson regional headquarters office.

United States

Amherst, Ohio
Telephone: 800.626.8303
Facsimile: 888.229.4580
Web: www.nordson.com/powder
Email: powder@nordson.com

www.nordson.com

Canada

Markham, Ontario
Telephone: 800.463.3200
905.475.6730
Facsimile: 905.475.8821

www.nordson.ca

Europe

Erkrath, Germany
Telephone: 49.211.9205.0
Facsimile: 49.211.254658
Email: info@de.nordson.com

Japan

Tokyo, Japan
Telephone: 81.3.5762.2700
Facsimile: 81.3.5762.2701

www.nordson.co.jp

Asia/Australia/Latin America

Amherst, Ohio
Telephone: 440.985.4000
Facsimile: 440.985.1096
24-hour message service:
440.985.4797

Email: intcustomerservice@nordson.com

